

Ferramentas de Gravação

Ângulos e Formatos

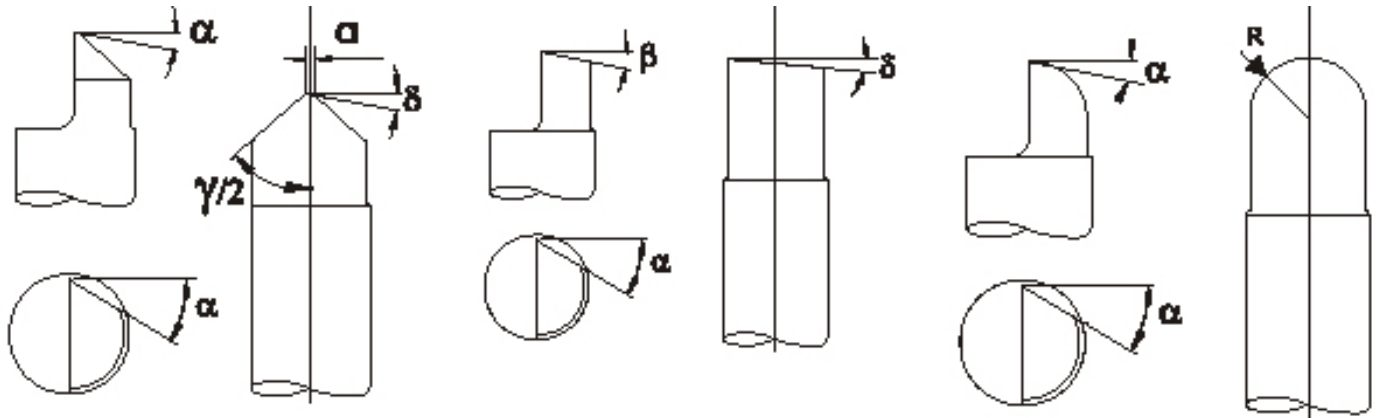

α = ângulo de corte ou saída

β = ângulo de alívio - só bits formato paralelo

δ = ângulo de alívio final

$\gamma/2$ = ângulo de perfil para bits cônicos

a = largura da ponta

R = raio para bits arredondados

Ângulos, em graus

Material a Usinar	α	β	δ
Aço, ferro	25	15	5
Latão, bronze	30	15	5
Alumínio, acrílico	30	15	5
Plásticos leves (ABS, PVC, Polietileno)	45	25	20



Cônico



Cônico Achatado

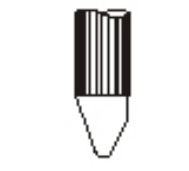

Cônico Arredondado



Cônico Achatado Arredondado



Cilíndrico Achatado

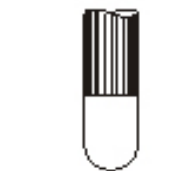

Cilíndrico Arredondado



Cilíndrico Canto Arredondado



Cilíndrico Côncavo

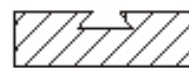

Cônico Invertido

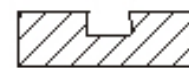

Cônico Invertido Arredondado



Circular



Duplo Quebrado

AVISO

AVISO INDÚSTRIA E COMÉRCIO LTDA.